

Dave Heineman
Governor

STATE OF NEBRASKA
DEPARTMENT OF NATURAL RESOURCES
Brian P. Dunnigan, P.E.
Acting Director

November 3, 2008

IN REPLY TO:

Mark Mainelli
Mainelli, Wagner and Associates
6920 Van Dorn Street, Suite A
Lincoln, NE 68506-2842

Dear Mr. Mainelli:

Attached are a Request for Engineering Services, drawings, and additional material related to the Guide Rock gage on the Republican River. We are asking that interested firms provide written qualifications by 5:00 pm, November 12, 2008. Thank you for your interest.

Sincerely,

Steve Gaul
Supervisor
Planning and Assistance Division

Attachments

11/3/08

Request for Engineering Services – Guide Rock Gage, Webster County Nebraska

The Nebraska Department of Natural Resources is seeking the services of a qualified registered professional engineer to prepare a report examining design, structural or maintenance deficiencies for the existing cableway for the Guide Rock Nebraska gaging station and evaluating the suitability of the gaging station and its infrastructure (especially the cableway) for human use and occupancy. The needed report is to also provide a description and detailed cost estimate of improvements or actions needed to make the station suitable for human use and occupancy. The report should also address the alternate possibility of modifying the existing cableway to work with a bank operated system at the same site. The gaging station is located at Lat. 40°04'08" Long. 98°22'25", and/or located approximately 0.2 mi downstream of the Courtland diversion dam on the Republican River or 0.5 mi south and 2 miles west of Guide Rock in Webster County, Nebraska.

It is expected that a follow-up visit to the site will be needed in order to inspect modifications and certify adequacy.

The standards and policies the station and cableway will need to meet include those described in the following sources provided by the U.S. Geological Survey which will be provided upon request: Chapter A-21 Streamgaging Cableways, U.S. Geological Survey – a publication that can be found on-line at http://pubs.usgs.gov/twri/twri3-a21/pdf/TWRI_3-A21.pdf ; Water Resources Division Memorandum No. 91.42, SAFETY – Plan for Insuring the Safety of Cableways; Water Resources Division Memorandum No. 2000.10, Policy and Guidelines for Surface-Water Gaging Station Stilling Wells That Meet OSHA's Definition of Confined Space; Job Hazard Analysis for Cableways; and Job Hazard Analysis for Confined Spaces. A copy of the most recent U.S. Geological Survey Inspection Report will also be provided upon request. Photographs of the site can be found at ftp://dnrftp.dnr.state.ne.us/pub/consdam/Flood_photos/Guide_Rock_Cableway_2008 . Finally, a drawing of the existing structure is also available upon request. It should be noted that it is intended that the existing stilling well be removed and filled with soil.

Please provide written qualifications and estimates of cost for these services to the Nebraska Department of Natural Resources by 5 pm November 13, 2008. Qualifications provided for the inspecting engineer should include any design or forensic experience with cableways, small suspended bridges or other relevant experience. Responses should be submitted for the attention of Steve Gaul, Supervisor, Planning and Assistance Division and may be e-mailed to sgaul@nebraska.gov .



United States Department of the Interior

U.S. GEOLOGICAL SURVEY
Nebraska Water Science Center
5231 South 19 Street
Lincoln, NE 68512-1271

RECEIVED

SEP 16 2008

DEPARTMENT OF
NATURAL RESOURCES

September 15, 2008

Brian Dunnigan
Department of Natural Resources
PO Box 94676
Lincoln, NE 68509-4676

Dear ~~Mr. Dunnigan:~~ ^{Brian}

This is in reference to the Nebraska Department of Natural Resources (NDNR) request to take over the old Republican River near Guide Rock (06853000) streamgaging station about 0.2 mi downstream of the Courtland diversion dam. As I am sure you are aware, the gage has been inactive for a number of years. The U.S. Geological Survey (USGS) was planning to dismantle the facilities at the site because of safety concerns—the stilling well is considered a confined space, and the cableway and car no longer meet USGS standards and are considered unusable in their current condition. There is also a concern about the lack of good access to the site. However, the NDNR is welcome to take the gage over as long as it is understood that they assume responsibility for the gage facilities in an “as is” condition.

Enclosed are two copies of Agreement for Gage Transfer No. 8-8626-06853000. The agreement includes a list of deficiencies in the facilities and a list of USGS safety policies regarding the gage. A requirement of the agreement is that a qualified non-USGS engineer examines the gage and prepares a report that evaluates whether it is suitable for use, with a copy provided to the USGS. Please sign both copies of the agreement and return one copy, along with a copy of the engineer’s inspection report, to this office.

As a required safety measure some time ago, we replaced the standard-keyed USGS padlocks with non-standard ones. The non-standard keys will be needed to gain full access.

Sincerely,

Robert B. Swanson, Director
USGS Nebraska Water Science Center

2 Enclosures

Republican River nr Guide Rock Cableway
Sta. No. 06853000

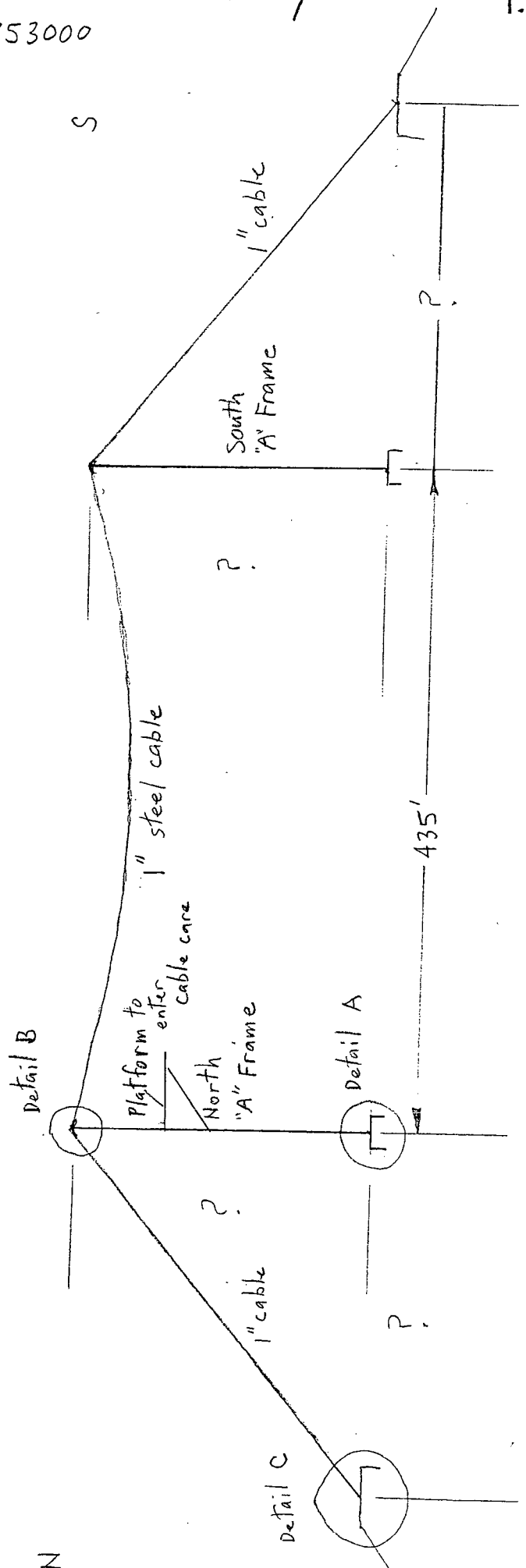

North A-Frame

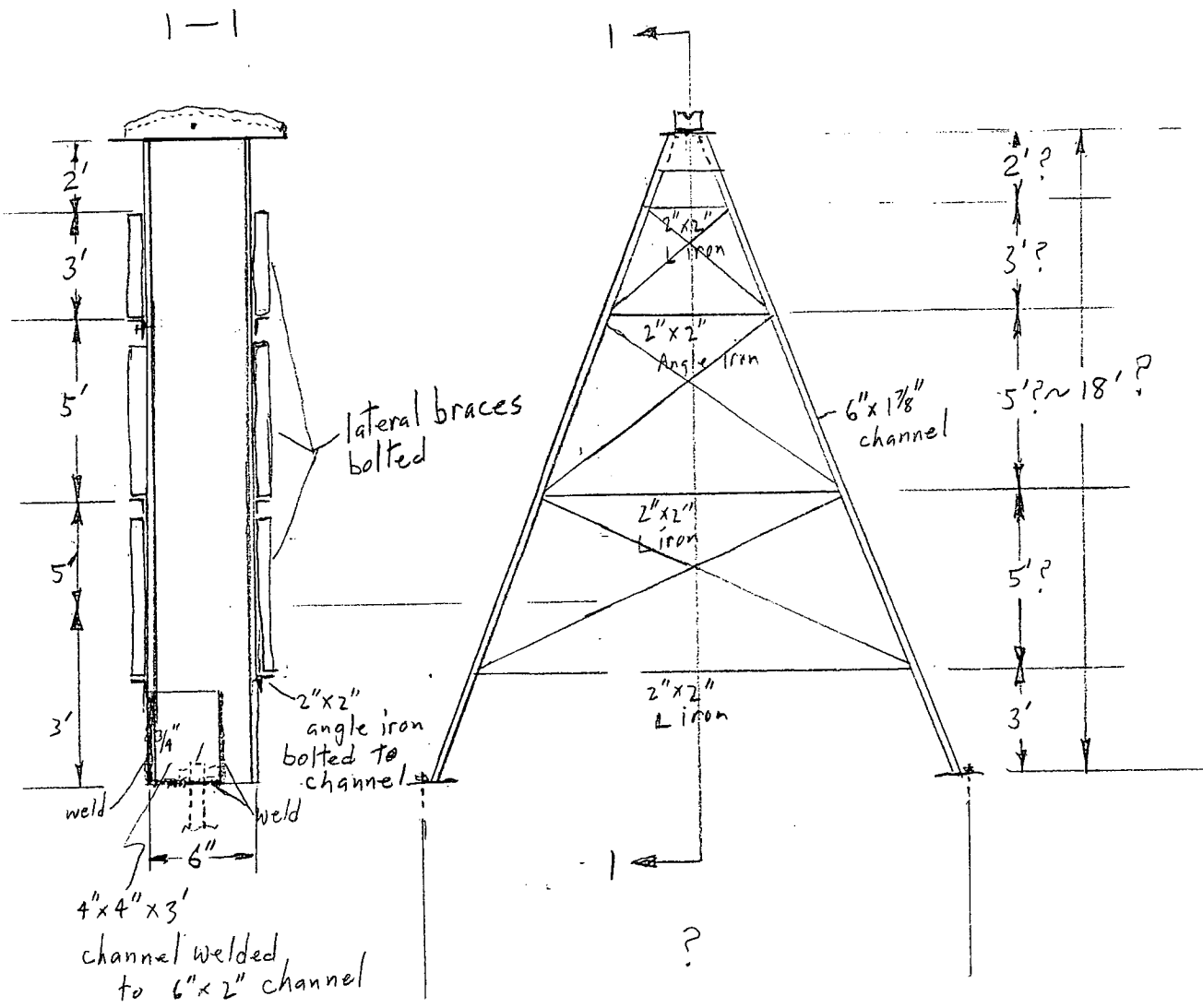

Detail A

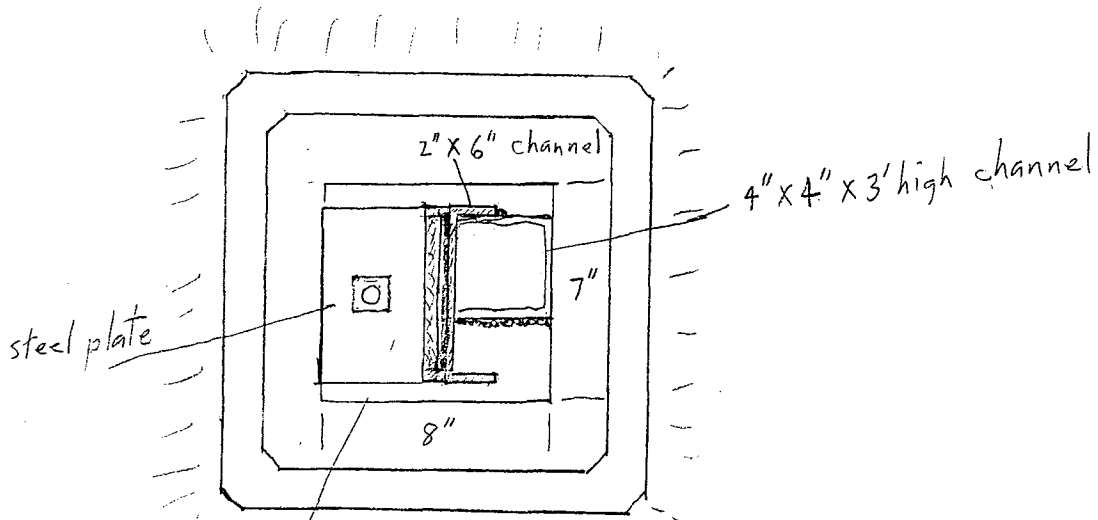

steel plate or angle iron bent to fit A-frame & welded to A-frame

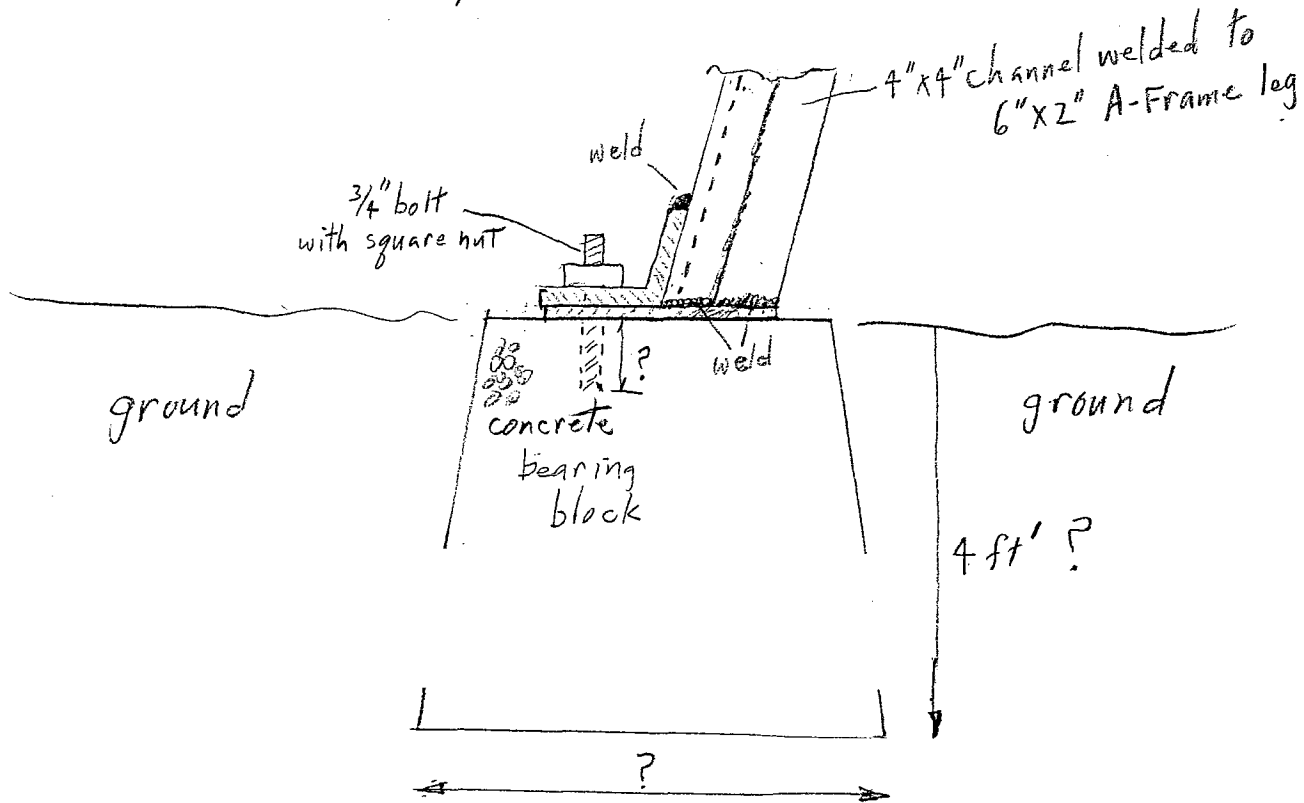

Detail B

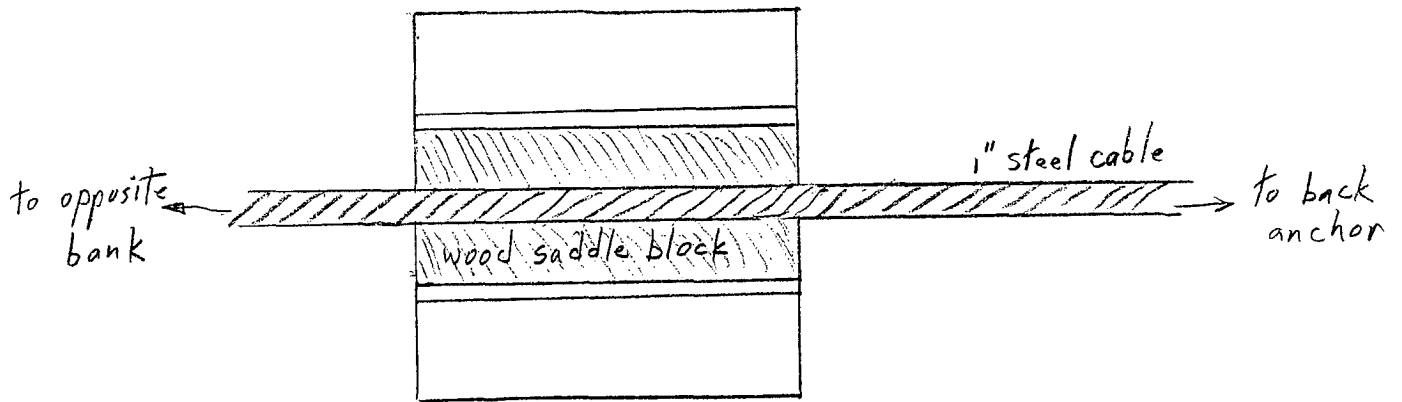
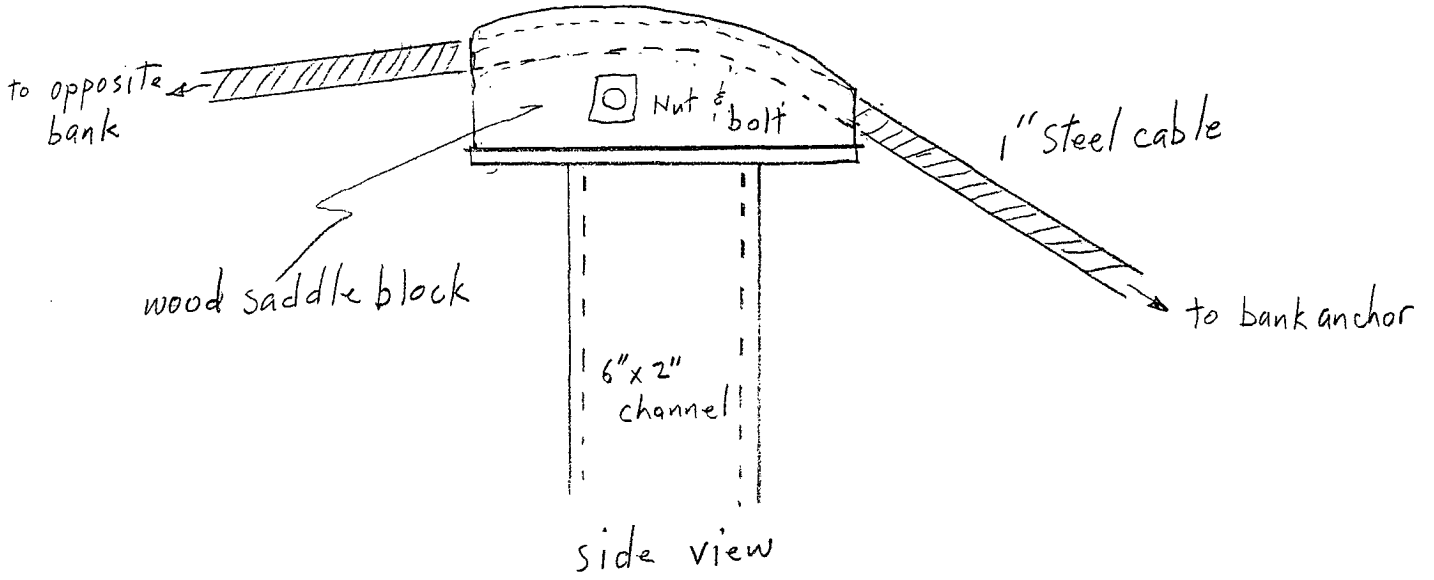

Back Anchor Block

Detail C

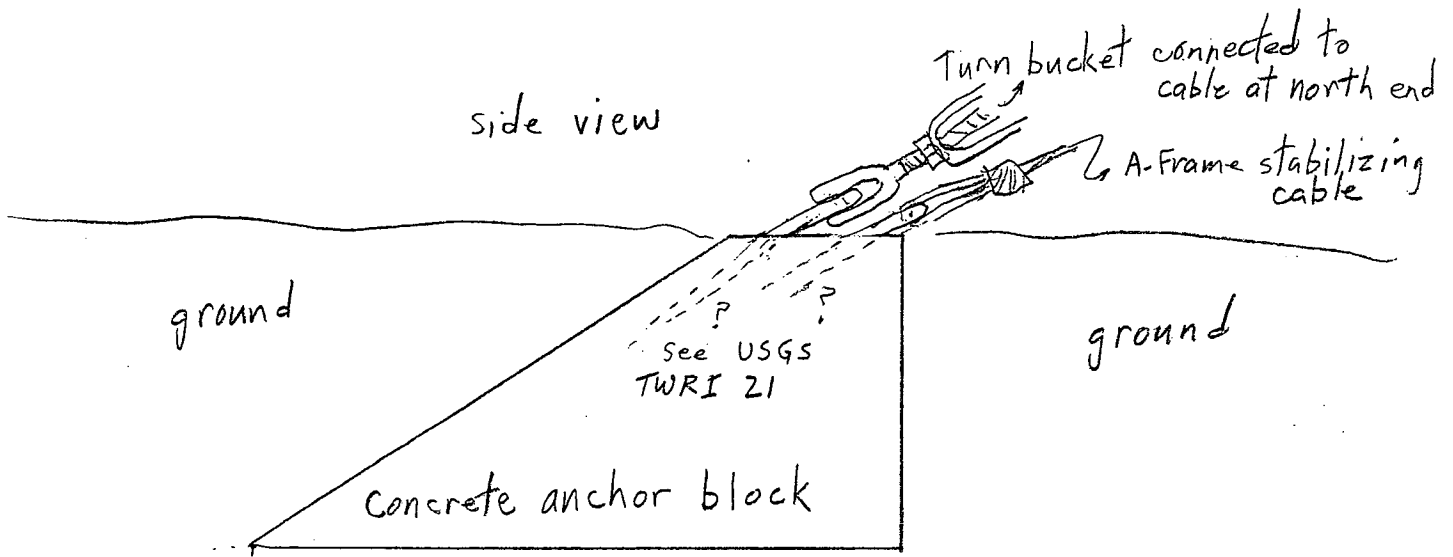
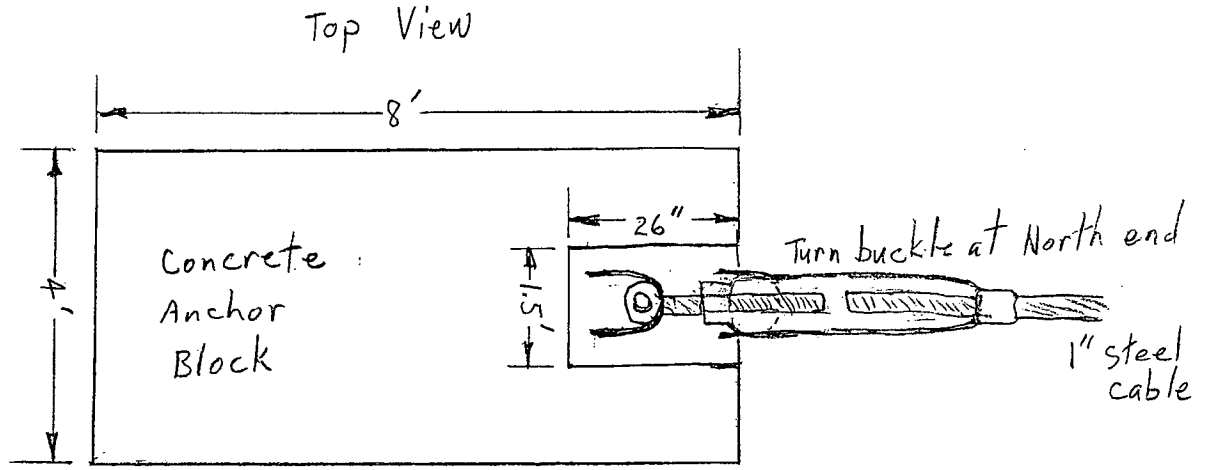

STREAMGAGING CABLEWAYS Western Region - Inspection Checklist

Station Name: Republican R. RR Guide Rock Number 06 8570.00
 Review previous inspection form. List any important notes:
 Cable Type: EEIP EIP SS Other; Cable Diameter: 1/8 in; Clear Span: _____ ft; Design Sag: _____ ft

Right (Left) Bank (cable-car side)

ANCHOR:
 Anchor Type: Miss - Sidetail - Rock (Vertical or Horizontal (U-bar or Pin) - Tree - Other Concrete)
 Dimensions: H W D: _____; Height above ground: _____; Tree species: _____; Tree diameter: _____
 Is U-bar installed in the vertical plane? Y N; at correct angle (in line with angle of main cable)? Y N
 Anchors clean of debris: Y N Soil Weeds Bushes Trees Other _____
 Signs of deterioration: Concrete Y N; Rock Y N; Tree Y N; Cable connections Y N
 If YES, Explain: Rust
 Fractures: Y N; Movement: Y N; Rust-Corrosion on U-bar Y N
 If YES, Explain: Surface Rust
 Notes: U-bolt/bar 7/8 in wide 1/4 u-bolt

FOOTERS:
 Footing type: Block Pier - Slab - Other _____
 Dimensions: H W D: _____; Height above ground level: _____; Remarks: drawings attached
 Support footers clean of debris: Y N Soil Weeds Bushes Trees Other _____
 Signs of deterioration of concrete: Y N; Fracture Y N; Movement Y N
 Attachments: Pins Y N; Other _____; Corrosion/Missing Nuts? Y N; Explain: _____
 Notes: _____

MAIN CABLE:
 Unloaded Sag: _____; Angle to anchor: _____; Cable Length (A-frame to anchor): _____
 U-bar to cable: Socket Turnbuckle - Clevis Direct (must have thimble) - Other _____
 Thimbles where required? Y N; Cable turnback length: _____
 Cable clips: Y N; Type: _____; Installed properly? Y N Explain _____
 Number: _____; Proper torque? Y N; Spacing: _____ inches
 Signs of deterioration to: Y N Cable Socket - Turnbuckle - Clevis - Thimbles - Clips - Other _____
 If yes, what? Rust - Corrosion - Flaking - Broken/Kinked strands - Items missing - Cracks - Other _____
 Explain: Some light rust is present mainly just surface rust
 Is main cable span free of debris, brush, and other obstructions: Y N
 Are cable car routes from A-frames to banks free of trees, brush, and other obstructions: Y N
 Other: _____

BACKSTAY/GUYLINES:

Cable use: Backstay - Guyline; Cable Type: EEIP EIP SS Other; Cable Diameter: 1/2 in
 Auxiliary U-bar(s)? Y N; Connection at A-frame: Eyebolt - Welded steel loop - Other Thimble
 Eyebolt/Loop diameter: _____; Forged? Y N; Shouldered? Y N; Remarks: _____
 U-bar to cable: Direct - Other _____; Thimbles where required? Y N; Cable turnback length: _____
 Cable clips: Y N; Type: _____; Installed properly? Y N Explain _____
 Number of clips: 1; Proper torque? Y N; Proper spacing: Y N; Spacing: _____ inches
 Signs of deterioration: Y N Cable - Eyebolt - Thimbles - Clips - Other _____
 If yes, what? Rust - Corrosion - Flaking - Broken/Kinked strands - Items missing - Cracks - Other _____
 Explain: _____

AIRCRAFT WARNING MARKER:

Is warning device required? (see WRD policy memo 2000.13): Y N
 Is warning device in place? Y N

CABLE SUPPORTS:

Support type: A-frame Steel - pipe - wood) - Tower - Vertical beam - Tree
 Base width: 9'; Height: 13'; Cross members? Y N; Tree species: _____; Tree diameter: _____
 Signs of deterioration: Y N; If yes, what? Fatigue Rings - Corrosion - Wood decay
 Explain: slight rust
 Configuration of base: Single - Hinge (pin); Are all components in place? Y N Explain: _____
 Platform: Y N; Material: W/P; Bolts/welds: VG P; Grated: Y N; Handrails: Y N
 Height above ground: 1'; Climbing device: Ladder Bolts - Steps - Other _____
 Is Fall Protection required: Y N
 Main cable support: Saddleblock - Sheave - Other _____; Diameter: _____; D/d ratio > 10: Y N
 Does groove size match cable diameter? Y N Explain _____
 Signs of deterioration of saddle block: Y N; If yes, what? Rust - Corrosion - Decay - Other _____
 Notes: _____

CABLE CAR:

Type: HIF Stand up - Sit down Has retrofit been installed? Y N
 Other Stand up - Sit down - Power; Material: Steel - Wood - Aluminum - Other _____
 Signs of deterioration: Y N; If yes, where? Hanger bars - Sheaves - Seats - Floors - Other _____
 What? Bent - Twisted - Deformed - Cracked - Rotted - Other _____
 Explain: _____
 Bolts/Nuts: Rusted - Loose - Missing - Other; Remarks: _____
 Overall condition based on visual inspection: Good Fair Poor
 Notes: Picture view to

Notes: Pictures 72-75 are N. side

Right Left Bank
(non-cable car side)

ANCHOR

Anchor type: Mass - Sidehill - Rock (Vertical or Horizontal/U-bar or Pin) - Tree - Other
Dimensions: H W D: Height above ground: ; Tree species: ; Tree diameter: Y
Is U-bar installed in the vertical plane? Y N; at correct angle (in line with angle of main cable)? Y N
Anchors clean of debris: Y N Soil Woods Bushes Trees Other
Signs of deterioration: Concrete Y N; Rock Y N; Tree Y N; Cable connections Y N
If YES, Explain: 11-1-03

Fractures: Y N; Movement: Y N; Rust/Corrosion on U-bar Y N
If YES, Explain: 11-1-03

FOOTERS: Pedestal - Pier - Slab - Other
Footings type: Mass - Sidehill - Rock (Vertical or Horizontal/U-bar or Pin) - Tree - Other
Dimensions: H W D: Height above ground level: ; Remarks:
Support footers clean of debris: Y N Soil Woods Bushes Trees Other
Signs of deterioration of concrete: Y N; Fractures Y N; Movement Y N
Attachments: Pins (Bolts) Other: Rust/Corrosion/Missing Nuts; Y N; Explain: 11-1-03

MAIN CABLE:
Unloaded Sag: ; Angle to anchor: ; Cable Length (A-frame to anchor): 35
U-bar to cable: Socket - Turnbuckle - Clevis - Dirret (must have thimble) - Other
Thimbles where required?: Y N; Cable turnback length: ;
Cable clips: Y N; Type: ; Installed properly?: Y N Explain: ;
Number: ; Proper torque?: Y N; Proper spacing: Y N; Spacing: inches
Signs of deterioration to: Y N Cable (Socket) Turnbuckle - Clevis - Thimbles - Clips - Other
If yes, what?: Rust - Corrosion - Flaking - Broken/Kinked strands - Items missing - Cracks - Other
Explain: 11-1-03

BACKSTAY/GUYLINES:
Cable use: Backstay - Guyline; Cable Type: EEIP EIP SS Other; Cable Diameter: in
Auxiliary U-bar(s)? Y N; Connection at A-frame: Eyebolt - Welded steel loop - Other
Eyebolt/Loop diameter: ; Forged?: Y N; Shouldered?: Y N; Remarks:
U-bar to cable: Direct - Other: ; Thimbles where required?: Y N; Cable turnback length: 5
Cable clips: Y N; Type: ; Installed properly?: Y N Explain: ;
Number of clips: 3; Proper torque?: Y N; Proper spacing: Y N; Spacing: inches
Signs of deterioration: Y N Cable - Eyebolt - Thimbles - Clips - Other
If yes, what?: Rust - Corrosion - Flaking - Broken/Kinked strands - Items missing - Cracks - Other
Explain: 11-1-03

CABLE SUPPORTS:
Support type: A-frame (steel) - pipe - wood) - Tower - Vertical beam - Tree
Base width: 2 Y Height: 10; Cross members?: Y N; Tree species: ; Tree diameter: ;
Signs of deterioration: Y N; If yes, what?: Fatigue - Rust - Corrosion - Wood decay
Explain: 11-1-03

Configuration of base: Rigid - Hinge (pin). Are all components in place? Y N Explain: ;
Platform: Y N; Material: ; Bolts/welds: VG G P; Grated: Y N; Handrails: Y N
Height above ground: ; Climbing device: Ladder - Bolts - Steps - Other: ;
Is Fall Protection required: Y N
Main cable support: Saddle block - Sheave - Other: ; Diameter: ; D:d ratio > 10: Y N
Does groove size match cable diameter?: Y N Explain: ;
Signs of deterioration of saddle block: Y N; If yes, what?: Rust - Corrosion - Decay - Other: ;
Notes: 11-1-03

Are office records describing this cableway system complete and accurate: Y N (Update as required)
What is the maximum stage this cableway can be safely used: ;
Is this stage posted in the gage house: Y N; Is this stage posted on the cableway: Y N
Notes: 11-1-03



Explanation for any of the above items considered: "UNSAFE"
1 CABLEWAY AREA IS OVERGROWN WITH TREES
2 CABLE CAR IS OLD WITH NO OTHER WOOD FLOOR
3 A-FRAMES HAVE SURFACE RUST
4 A-FRAME BOLTS TO PIER ARE RUSTY
5 ACCESS TO CABLEWAY IS NOT GOOD
6 THERE IS EXTREME OVERFLOW AROUND
7 BOTH TOWERS

*** If cableway system is determined to be UNSAFE, it must be removed from service until repairs can be made. Lock the cablecar with a non-USGS lock or remove the cablecar completely at this time.
A 6th WAY SHOULD NOT BE USED
I certify that the inspection was conducted on this date, all elements of the cableway were checked, deficiencies found were noted on the hazard elimination log, and if necessary, the cablecar was locked or removed until repairs can be made.
Inspected by: K. R. [Signature] Title: Hydro Tech Date: 10-9-03
Reviewed by: _____ Title: _____ Date: _____



**Bureau Policy--SM 445-2-H Chapter 15 (Job Hazard Analyses)
Bureau Policy--SM 445-2-H Chapter 40 (Confined Spaces), Appendix 40-1**

Policy and Guidelines for Surface-Water Gaging Station Stilling Wells That Meet OSHA's Definition of Confined Space

In Reply Refer To:
Branch of Operational Support
Mail Stop 405
Sunset Date: April 2005

May 3, 2000

WATER RESOURCES DIVISION POLICY MEMORANDUM NO. 2000.10

Subject: Policy and Guidelines for Surface-Water Gaging Station Stilling Wells That Meet OSHA's Definition of Confined Space

Many Water Resources Division (WRD) stilling wells used at surface-water gaging stations meet the definition of confined space as defined by Title 29 of the Code of Federal Regulations (CFR) sections 191.146. The Occupational Safety and Health Administration (OSHA) requires employees to be protected from hazards associated with confined space entry. The confined space hazard in stilling wells is real. It is easy, however, to become complacent about this hazard because of the lack of recent serious accidents. The probability of a serious accident in a stilling well is low, however, the results can be fatal. A fatal accident that occurred in August 1960 is described below:

An employee was "mucking out" a well on the Arkansas River near Little Rock. The stilling well was constructed of cement and 30-40 feet deep. A gasoline-powered pump was tied to the stilling well ladder and was being used to lower the water in the well and pump out the mud. Tubing was used to vent the exhaust outside the well. Exhaust fumes that inadvertently leaked into the well overcame the employee in the well and caused him to pass out. A student assisting at the site turned off the pump and tried, but was unable to remove the employee from the well. The student began to seriously suffer from the exhaust fumes in the well, so he tied off the employee to the stilling well ladder and sought help from railroad personnel working nearby. When help arrived, the water in the stilling well had risen and engulfed the employee. It is unknown if the employee died as a result of the exhaust fumes or drowned. The need to address the confined space in stilling wells has been addressed by two committees, the WRD Confined Space Subcommittee and the WRD Safety

Committee. After considerable review, policy and guidelines have been developed on safe entry to existing stilling wells. The policy and guidelines are provided in the attached document and are effective immediately. They apply only to those stilling wells that must be physically entered as a requirement of station operation and meet the definition of a confined space. New stilling wells with a confined space hazard should not be constructed unless alternative procedures to collect the required data are not technically feasible.

Any questions regarding this policy and guidelines should be directed to your Regional Safety Officer.

/SIGNED/

Catherine L. Hill
Associate Chief Hydrologist
for Program Operations

- 8 Attachments
- [Attachment1](#)
- [Attachment2](#)
- [Attachment3](#)
- [Attachment4](#)
- [Attachment5](#)
- [Attachment6](#)
- [Attachment7](#)
- [Attachment8](#)

This Policy Memorandum supersedes previous WRD Memorandums No. 94.30 and No. 97.32.

Email Distribution: A, B, S, FO, PO,
GW-W Safety Com,
GS-W SO,
GS-WRD Archive

You may need to select "Launch" rather than "View" to see some of the attachments.

----- Catherine L. Hill Associate Chief Hydrologist for Program Operations
chlhill@usgs.gov 441 National Center 703-648-5031 (Phone) U.S. Geological Survey 703-648-5295 (Fax) Reston, Va 20192



Bureau Policy--SM 445-2-H Chapter 41 (Cableway Safety)
Bureau Policy--SM 445-3-H Topic 29 (Cableway and Gaging Stations)

SAFETY - Plan for Insuring the Safety of Cableways

In Reply Refer To:
Mail Stop 405

June 25, 1991

WATER RESOURCES DIVISION MEMORANDUM NO. 91.42

Subject: SAFETY - Plan for Insuring the Safety of Cableways

The Water Resources Division (WRD) uses over 1,600 Cableways across the country. The purpose of this plan is to help insure these cableways are structurally sound, well maintained, and safely used. The plan describes the direction the WRD will take in implementing cableway safety. Policy memorandums will be issued separately for each topic.

The plan proposes three levels of cableway inspection; outlines the training requirements of personnel who inspect cableways, use cableways, and review cableway construction; and defines the planning and review procedures for construction or major rehabilitation of cableways.

1. Cableway Inspection, Evaluation, and Restoration

Cableways--a cable, anchor, support structures, cable car, stays, guy wires, and other appurtenances--are subject to damage and deterioration from temperature changes, moisture, and vandalism. The integrity of the structure also may be threatened by erosion caused by overland runoff or by flooding. Because of this, cableways must be carefully monitored on a continuing basis and all defects corrected promptly to be sure they are safe for use by WRD personnel. To this end, the following procedures for inspection and testing will be implemented as follows:

A. Annual WRD Inspection

Each cableway will be inspected annually by trained WRD personnel. Cableways failing the inspection will not be used until the deficiencies are corrected. For example, if one clip is missing from either the main cable or the backstay, the cableway must not be used until the clip is replaced.

1. An inspection sheet (attachment A) will be filled out at the time of each annual cableway inspection and submitted to the inspector's supervisor. All deficiencies found during the inspection will be noted on a hazard elimination log (attachment B).
2. The District Chief or a designee of the District Chief will review all hazard elimination logs each October to insure that hazards found during the inspection have been corrected or the use of the cableway has been suspended. Any hazards should have been eliminated shortly after they were found.
3. In October, the District Chief will report in writing to the Regional Hydrologist that all district cableways were inspected during the preceding water year, and confirm that either the deficiencies were corrected or the use of the affected cableways

has been suspended. The report will contain a list of cableways identifying the deficiencies corrected or those cableways suspended from use. The lists will include estimated costs to correct the deficiencies and for rehabilitating those cableways suspended from use.

4. In November, the Regional Hydrologists will advise the Assistant Chief Hydrologist for Operations in writing that all cableways in their respective regions have been inspected within the preceding water year and that any deficiencies found have been remedied or that cableways with continuing defects have been taken out of service. The list requested in paragraph 3 above will be included in this report.
5. The Assistant Chief Hydrologist for Operations will be responsible for monitoring this inspection process and will provide a written report by December 20 each year to the Chief Hydrologist. The Assistant Chief Hydrologist for Operations will maintain a file of the cableway deficiencies found and corrected.

B. Inspection Prior to Use

Before using a cableway, every employee shall--to the extent possible--perform a quick visual inspection of the cableway. A notice similar to that in attachment C shall be posted in each gage house as a reminder and guide for the visual inspection.

C. Cableway Evaluation and Nondestructive Testing

Available information for each cableway will be researched and evaluated to determine the adequacy of the cableway to carry the design load. A thoroughly trained specialist will conduct or review the evaluation. The evaluation will include: (1) a detailed field inspection; (2) consideration of the need for nondestructive testing; and (3) identification of deficiencies that must be corrected before the cableway can be authorized for use. A minimum of 20 percent of the cableways will be evaluated each year beginning in fiscal year (FY) 1992 and ending in FY 1996 when the evaluations will be complete for all cableways.

The purpose of nondestructive testing is to identify and evaluate unknown deficiencies or deterioration of cableways and should not be undertaken to gain a few more years of use for marginal cableways. A nondestructive test should not be undertaken before a cableway has been visually inspected or a visual inspection indicates that repairs are needed.

Nondestructive testing is defined as: (1) the magnetic testing of the cableway for loss of metallic area and location of defects in the cable and (2) the load testing of a cableway with a 2,000 pound deadload or with the design load of the cableway, whichever is larger. Suitably trained WRD personnel or a contractor will perform the nondestructive testing.

Attachments D and E describe how an evaluation will be made for determining if nondestructive testing is required for the main cable and the anchors, respectively.

The WRD will develop criteria for determining when a magnetometer test is required. The criteria could take into account the age of the cableway and the climate in which the cableway is located. The criteria do not preclude performing a magnetometer test at

**U.S. DEPARTMENT OF THE INTERIOR
U.S. Geological Survey
Agreement for Gage Transfer**

The U.S. Geological Survey (USGS) agrees to transfer ownership of the gaging station infrastructure, which includes a corrugated-metal stilling well/shelter with attached stairs, cableway with car, and related fencing,

(Description of stilling well, walkways, shelter, cableway, and any other structures and/or attach map, plat, drawings, photographs, or other descriptive information.)

hereinafter referred to as "the gaging station" located at Lat. 40° 04' 08" Long. 98° 22' 25", and/or located 0.2 mi downstream of the Courtland diversion dam on the Republican River 0.5 mi south of Guide Rock in Webster County, Nebraska

(Provide other location description and/or attach map, plat, drawings, photographs, or other descriptive information.)

to Nebraska Department of Natural Resources,

(Name of state or local, or tribal government, or Federal Energy Regulatory Commission licensee)

hereinafter referred to as the "Transferee," giving the Transferee all rights to the gaging station. The Transferee agrees to assume all responsibility for the above-described gaging station.

Check as Applicable:

to the best of its knowledge, the USGS is unaware of any design, structural, or maintenance deficiencies.

(or)

to the best of its knowledge, the USGS is unaware of any design, structural, or maintenance deficiencies except for the following.

The cableway and car do not meet USGS standards and are not considered usable without repairs or changes. Wooden components of the gaging station (such as stairs, railings, gage floor, tower platform, cable car floor, and cable saddles) are old and could be weak; the cable car floor is known to be cracked and rotted. The concrete cable anchors and tower footings have become buried or show signs of deterioration. Attachments to the buried cableway anchors and tower footings have probably corroded. The cableway and towers have rust on them. The area is overgrown with brush and trees that obstruct passage of the cable car and could fall onto the cableway.

The Transferee agrees to accept the gaging station "as is" and not to hold the USGS or the U.S. Government responsible in any way for any design, construction, or maintenance deficiencies or repairs that may be required on the gaging station to meet any safety, government, or other standard. After transfer, the USGS will have no further duty to inspect or maintain the gaging station. The Transferee agrees to assume those duties. The Transferee further agrees to: (a) accept responsibility for any liability, such as liens, fines, damages, penalties, forfeitures or judgments arising from the continued use or existence of the gaging station; (b) release the USGS and the U.S. Government from liability for any injuries or damage to persons and/or property of any kind arising out of the continued use or existence of the gaging station; and (c) indemnify the USGS and the U.S. Government from any claims arising out of the use or existence of the gaging station. If Transferee chooses or is forced to abandon the gaging station, Transferee agrees to assume full responsibility for its disposition in compliance with applicable federal, state and local laws.

**Agreement for Gage Transfer
(Continued)**

The Transferee has provided the USGS a copy of its signed agreement with the landowner granting the Transferee permission to operate and maintain the gaging station.

The USGS has provided the following USGS and local district safety policies pertaining to the transferred gaging station:

Water Resources Division Memorandum No. 91.42, SAFETY - Plan for Insuring the Safety of Cableways (attached); Water Resources Division Memorandum No. 2000.10, Policy and Guidelines for Surface-Water Gaging Station Stilling Wells That Meet OSHA's Definition of Confined Space (attached); Job Hazard Analysis for Cableways (attached); and Job Hazard Analysis for Confined Spaces (attached); copy of the last USGS cableway inspection report (attached).

Prior to the transfer, the Transferee agrees to have a qualified non-USGS engineer prepare a report examining whether the gaging station has design, structural, or maintenance deficiencies, and evaluating the suitability of the gaging station for the use(s) intended. The Transferee agrees to retain a copy of the engineer's report and provide a copy to USGS.

U.S. GEOLOGICAL SURVEY

By

Robert B. Swanson

Date: Sep 15, 2008

Transferee
By

Date: _____

Notary Seal:

any time. Any main cable regardless of age should be tested if the WRD inspector suspects diminishment of cable integrity.

Training courses will be developed at three levels: (1) for all employees who use the cableways to measure or sample; (2) for those employees who perform the annual inspection; and (3) for those employees who serve as the cableway experts in the districts and regions.

c

The WRD will develop by September 30, 1991, a training course on safety practices and on inspections to be conducted prior to each use of cableways. This training will be made available to the districts and provided to every employee that uses cableways. The course will include a combination of classroom lecture, video presentation, and on-site training. The complete course will be mandatory for all new employees who may use cableways and for potential cableway users who do not have experience on cableways. The classroom and video training will be mandatory for all employees who use cableways regardless of experience.

A training course for those employees who will conduct the annual inspection will be developed by September 30, 1991. Training on how to conduct the annual visual inspection of cableways and on construction of cableways has been presented in all four regions within the past year. The training course being developed will be an appropriate modification and will include some theory on design considerations, extensive discussion, lecture, and video presentations on potential deficiencies and on inspection procedures to detect problems.

Training for personnel selected to be the District and Regional Cableway Specialists will include, in addition to the training for the annual inspectors, more concentrated course work on the theory of cableway design and construction.

It is recognized that training in all aspects of cableway safety will not be completed for the 1991 annual inspections. Until such training is complete, the annual inspections should proceed utilizing to the fullest extent possible those personnel who have attended the cableway inspection and construction course presented last year.

3. Cableway Construction

Cableways must be constructed properly to insure the safety of WRD employees who use them. The Division is in the process of updating Circular 17 "Structures for Cableways." As of the date of this memorandum, all new construction or substantial rehabilitation of cableways shall meet the criteria of the revised manual which is Open-File Report No. 91.48 "Streamgaging Cableways." The following procedure will be followed when new cableways are constructed:

A Review of Cableway Construction Design Plans

1. A minimum of two hydrologist [Ds will be selected and trained in each region to serve as consultants to districts for cableway construction or major rehabilitation and to review new cableway construction design. These cableway specialists may be District or Regional Office personnel.
2. Districts planning to construct new cableways or perform major rehabilitation will submit for a design plan to the appropriate Cableway specialists for review and approval.

B. Design Information

The design plan will include: the information specified in the "Cableway Design Summary" in Open-File Report No. 91.48 (attachment F); sketches of the A-Frame, A-Frame base, anchorage, and landing platforms; a cross section of the channel from anchor to anchor, and the maximum measuring stage permitted from the cable.

C. Review of Construction

Following construction, the District Chief will provide a letter to the Regional Hydrologist that the installation was inspected by a designated cableway specialist and that it was constructed according to the approved plans.

Philip Cohen

Attachments

(Contact the Branch of Operational Support, Reston, for a copy of the attachments).

Distribution: A,B,S,FO,PO

KEY WORDS: Cableway Safety, Training, Inspections



CONTENTS

- 1. INTRODUCTION**
- 2. GENERAL GUIDELINES TO ENTER STILLING WELLS**
- 3. GUIDELINES FOR STILLING WELLS THAT FAIL ANY ATMOSPHERIC TEST**
- 4. APPENDICES**
 - A. Stilling Well Entry Sign**
 - B. Stilling Well Safety Evaluation Form**
 - C. Example of a Job Hazard Analysis**
 - D. Summary of Basic Entry Requirements for Stilling Wells**
 - E. Summary of Entry Requirements for Stilling Wells that have Failed any Atmospheric Test**
 - F. Frequently Asked Questions**

1. INTRODUCTION

This safety policy and set of guidelines establishes specific safety standards and safe work practices for all WRD stilling well operations that meet OSHA's definition of confined space. A confined space is a space that is large enough and so configured that an employee can bodily enter and perform assigned work, has limited or restricted means for entry or exit, and is not designed for continuous employee occupancy.

Field personnel, supervisors, and managers are all responsible for safety in the workplace (Executive Order 12196, "Occupational Safety and Health Programs for Federal Employees" and OSHA regulation 29 CFR 1960). "Basic Program Elements for Federal Employee Occupational Safety and Health Programs and Related Matters" require that supervisors and managers be responsible and accountable for correcting existing and potential hazards, and for providing a safe and healthy workplace and working conditions. It is, therefore, the responsibility of managers and supervisors to ensure that the safety procedures and guidelines prescribed in this document are followed for all stilling wells that meet OSHA's definition of confined space.

2. GENERAL GUIDELINES TO ENTER STILLING WELLS

A. Provide engineering solutions to reduce the need to enter the stilling well. For example, an electric tape can be used to measure water levels in the stilling well rather than entering the well to read a staff gage.

B. Place a sign at every entry to the stilling well: "Safety Hazard Unauthorized Personnel DO NOT ENTER" (example provided in Appendix A). Cooperators or other non-USGS personnel visit many USGS gaging stations. The purpose of the sign is to warn everyone who may have access to the stilling well that there is a hazard and they should not enter.

C. Conduct a safety evaluation of the gaging station stilling well. Safety evaluations should be conducted either annually or just prior to entry. Personnel who conduct the safety evaluation for both physical and electrical safety hazards must have the necessary experience and skills needed to complete the evaluation. Personnel who conduct the atmospheric tests need to be trained to calibrate and use the instrumentation. Safety evaluation guidelines are described below:

1. Document the number of years the stilling well has been safely entered. Review historic safety evaluations/incidents to help identify potential safety concerns.
2. Evaluate and eliminate all identified physical hazards.
 - a. Are ladders safe? Is fall protection needed? Fixed ladders require a safety device if they are more than 20 feet high (29 CFR 1917.118).
 - b. Objects such as tools, shovels, sounding weights, nitrogen tanks, etc. that could fall into the stilling well should be secured or removed. Personal protective gear (hard hat, rubber gloves, eye protection, etc.) must be available and used as appropriate.
3. Evaluate and eliminate all identified electrical hazards.
 - a. All AC electrical circuits in gaging stations and stilling wells must be protected by a Ground Fault Circuit Interrupter (GFCI) device.
 - b. Electric power tools used in stilling wells must be double-insulated or connected to a GFCI circuit.
4. Evaluate and eliminate all identified biological hazards such as sanitary concerns, snakes, wasps, mice (hantavirus), bats (histoplasmosis), etc.
5. Measure and verify that oxygen and carbon monoxide concentrations in the stilling well are safe (before mechanical ventilation).
 - a. Before entry into any stilling well, open all doors and vents for a minimum of five minutes. Doors should always be secured in the open position to prevent inadvertent entrapment. Measure the atmosphere in the stilling well near the expected breathing zone

of an entrant.

Oxygen concentration is acceptable if it is between 19.5% and 23.5%.

Carbon monoxide concentration is acceptable if it is 0 to 35 PPM.

6. Determine if there are other potential atmospheric concerns in the stilling well in addition to carbon monoxide and oxygen. All potentially hazardous atmospheric conditions must be evaluated and determined to be safe (before mechanical ventilation). For example:

a. Propane heaters in stilling wells can create very dangerous confined space hazards.

The propane may leak, displacing oxygen.

The propane may leak, creating an explosive hazard.

The propane heater may burn inefficiently, creating carbon monoxide.

The propane heater may consume the oxygen in the stilling well.

If propane heaters are used, the entry procedures for stilling wells that fail any atmospheric test, described later, must be used.

b. If there is considerable organic debris in the bottom of the stilling well, carbon dioxide may be displacing oxygen.

D. The results of the stilling well safety evaluation for physical, electrical, biological, and atmospheric hazards must be documented. An example of a form used to document the safety evaluation is included in Appendix B. Documentation should be filed in a manner that will allow field personnel easy access. The Stilling Well Safety Evaluation provided in Appendix B (excluding the atmospheric testing section) can also be used as a quick safety checklist prior to every entry.

E. A Job Hazard Analysis (JHA) that describes the hazards and the required safe entry procedures for working in stilling wells must be completed. The JHA should include a plan for emergency help such as phone numbers for rescue and medical help. Supervisors will discuss the JHA and safe entry procedures with every employee who may enter a stilling well. The JHA should be placed in the field folder for that gage. An example of a JHA for a stilling well with a confined space hazard is provided in Appendix C.

F. After steps A-E have been completed, provide mechanical ventilation, such as a portable blower, to supply fresh outside air into the stilling well during every entry. The blower should be able to supply enough fresh air to replace the total volume of air within the stilling well three times each minute. The fresh air exhaust duct from the blower should be placed near the water surface in the stilling well. Exhaust from gasoline or propane powered sources must be vented downwind and down gradient from the stilling well and the mechanical blower, to prevent accidental introduction of contaminated air in the stilling well.

A summary of these General Entry Requirements is provided in Appendix D.

3. GUIDELINES FOR STILLING WELLS THAT FAIL ANY ATMOSPHERIC TEST

If any atmospheric test is unacceptable, it is recommended that the use of the stilling well be discontinued and alternate methods to measure stage be used.

If entry into a stilling well that has failed any atmospheric test is needed, significantly more restrictive entry procedures must be used. These entry requirements must be used **every** time the stilling well is entered during the life of the stilling well:

- A. Use the General Guidelines for Entering Stilling Wells outlined in steps A – E above. In addition:
- B. Require a minimum of two people, an entrant and an attendant, every time the stilling well is entered.
- C. Provide mechanical ventilation, such as a portable blower, to supply fresh outside air into the stilling well during entry. The blower should be able to supply enough fresh air to replace the total volume of air within the stilling well three times each minute. The fresh air exhaust duct from the blower should be placed near the water surface in the stilling well. Exhaust from gasoline or propane powered sources must be vented downwind and down gradient from the stilling well and the mechanical blower, to prevent accidental contamination of air in the stilling well.
- D. Measure the stilling well atmosphere near the expected breathing zone of the entrant *during* mechanical ventilation for oxygen, carbon monoxide and any other atmospheric hazards identified as part of the safety evaluation.

Oxygen concentration is acceptable if between 19.5% and 23.5%.

Carbon monoxide concentration is acceptable if between 0 to 35 ppm.

If propane is used to heat the stilling well during the winter:

1. The propane must be turned off prior to entry.
2. The first atmospheric test must be for oxygen concentration (most combustible gas meters will not provide reliable readings in an oxygen-deficient atmosphere).
3. The next atmospheric test must be for combustible gas.

Combustible gas is acceptable if below 10% of Lower Explosive Limit.

4. The next atmospheric test should be for carbon monoxide concentration.

If any atmospheric measurement is unacceptable, even with mechanical ventilation, do not enter. This stilling well must be treated as a "Permit-Required Confined Space." Contact your Regional Safety Officer for further instructions.

E. If all atmospheric measurements are acceptable, continue to mechanically ventilate the stilling well and enter the well. The attendant will continuously monitor the stilling well atmosphere, near the breathing zone of the entrant, from outside the stilling well. **If atmospheric monitoring indicates unsafe conditions, the entrant must exit the stilling well immediately.**

A summary of the entry requirements for stilling wells that have failed any atmospheric test is provided in Appendix E. Answers to frequently asked questions are provided in Appendix F.

Appendix A





Appendix B

2/99

STILLING WELL SAFETY EVALUATION

District _____ Office _____

Station number/name _____ / _____

Inspector _____ Date _____

Inspect stilling well for hazards such as:

- * Unsafe ladders-(Ladders over 20 feet long require a fall-protection safety device)
- * Dangers from falling equipment
- * Potential for engulfment (drowning)
- * Electrical hazards (GFCI circuits required)
- * Biological hazards such as sanitary concerns, snakes, wasps, mice (hantavirus), bats (histoplasmosis) etc.
- * If electric power tools are used, they must be double insulated or connected to a GFCI circuit.

Describe all hazards identified and how each hazard was eliminated:

ATMOSPHERIC MONITOR: Meter Type _____ Serial No. _____

Date of calibration ____/____/____

Atmospheric Tests

Test	Acceptable Entry Conditions	Surface Air Reading Outside Well	Atmospheric reading in stilling well
Oxygen	19.5% to 23.5%		
Carbon monoxide	0 to 35 ppm		



APPENDIX C: EXAMPLE OF A JOB HAZARD ANALYSIS		
JOB: Entering Stilling Well with a Confined Space Hazard		DATE: 6/23/99
		Page: 1 of 2
PREPARED BY:		
REVIEWED BY:		
	Recommended Protective Clothing and Equipment: Portable electric blower, hard hat, gloves, steel-toed shoes, fall-protection equipment, cell phone, first aid kit, Personal Flotation Device (PFD)	
Sequence of Basic Job Steps	Potential Accidents/Hazards	Recommended Safe Job Procedures
Prepare for field trip.		Review WRD Policy Memo 2000.10 "Policy and Guidelines for Surface Water Gaging Stations that meet OSHA's Definition of Confined Space."
Find documentation for latest safety evaluation at this site.		Ensure that the safety evaluation for this site has been completed within the last 12 months.
Load required safety equipment. Equipment Checklist: 1. Electric blower 2. Ducting 3. PFD 4. Fall-protection equipment 5. Cell phone 6. First Aid Kit	Back Strain	Use proper lifting techniques. Get help for heavy equipment
	Pinching Fingers and Toes	Wear gloves and steel-toed boots.
	Unsecured Load	Ensure load is properly secured in field vehicle in case of an accident.
Open door to gaging station and stilling well.	Inadvertent Entrapment	Secure doors in open position.
Entering stilling well.	Unknown Hazards that may have developed since last visit Physical Hazards Electrical Hazards Biological Hazards	Perform a quick visual safety inspection using the Stilling Well Safety Evaluation Form as a checklist.



APPENDIX C: EXAMPLE OF A JOB HAZARD ANALYSIS		
JOB: Entering Stilling Well with a Confined Space Hazard		DATE: 6/23/99
		Page: 2 of 2
PREPARED BY:		
REVIEWED BY:		
	Recommended Protective Clothing and Equipment:	
	Portable electric blower, hard hat, gloves, steel-toed shoes, fall-protection equipment, cell phone, first aid kit, Personal Flotation Device (PFD)	
Sequence of Basic Job Steps	Potential Accidents/Hazards	Recommended Safe Job Procedures
Entering stilling well (continued)	Confined Space Hazards	Set up ventilation equipment.
	Atmospheric Hazards	Fresh air duct should be placed in the stilling well near the water surface.
		Gasoline-powered equipment must be located downwind and down gradient of stilling well to prevent accidental contamination of the stilling well atmosphere.
	Falling Objects	Secure or remove any equipment that may fall into the stilling well.
	Falling Hazard	Set up and wear fall-protection equipment.
Load equipment after completing the job.	Entrapment Hazard	Wear PFD; use two people at site.
	Back Strain	Use proper lifting techniques.
	Pinching Fingers and Toes	Wear gloves and steel-toed boots.
	Unsecured Load	Ensure load is properly secured in field vehicle in case of an accident.
		Emergency Phone Numbers:
		Police 777-777-7777
		Hospital 888-888-8888
		Fire-Rescue 999-999-9999



Appendix D. Summary of Basic Entry Requirements for Stilling Wells

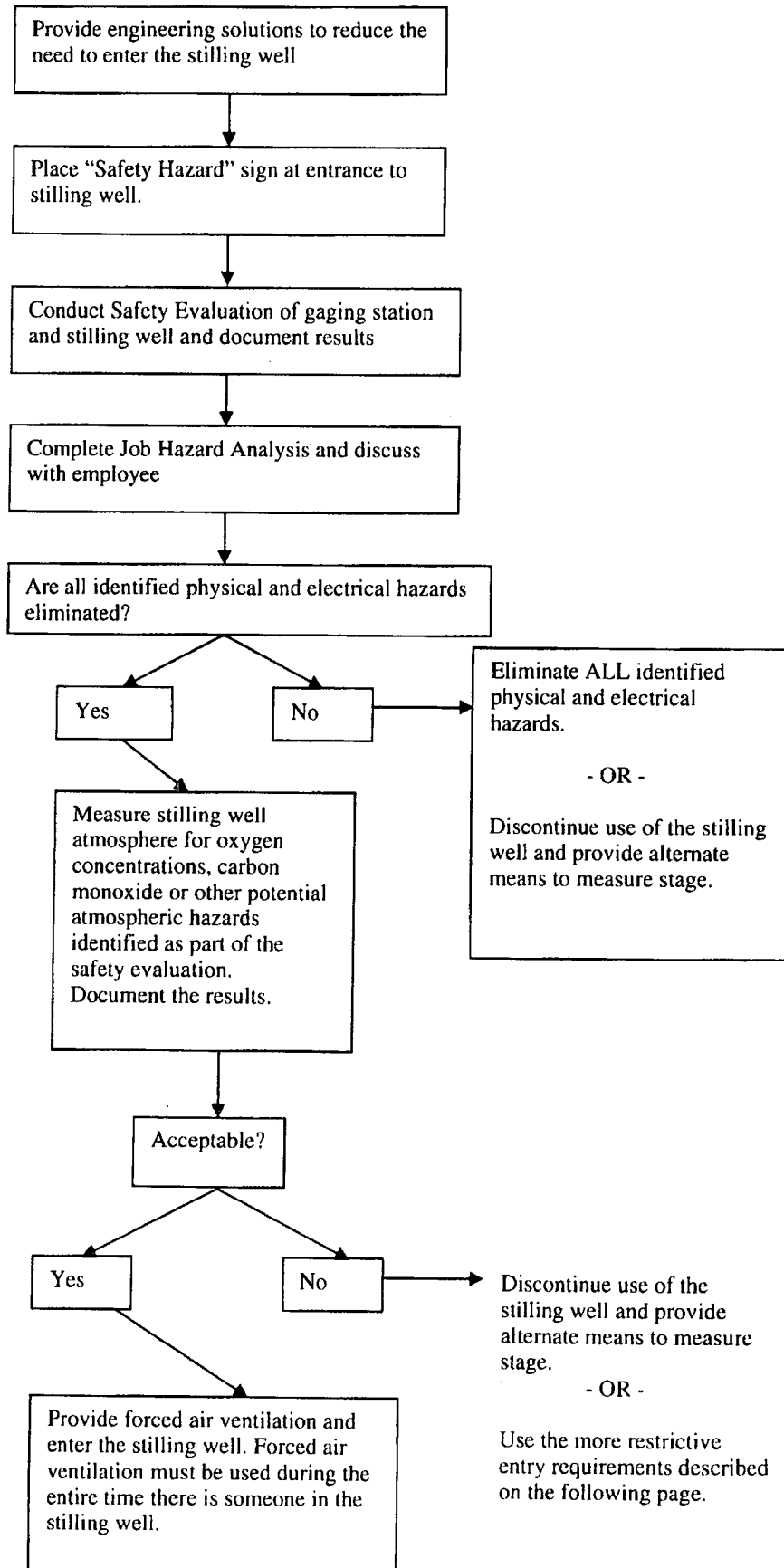

| |



Appendix E. Summary of Entry Requirements for Stilling Wells that have Failed any Atmospheric Test

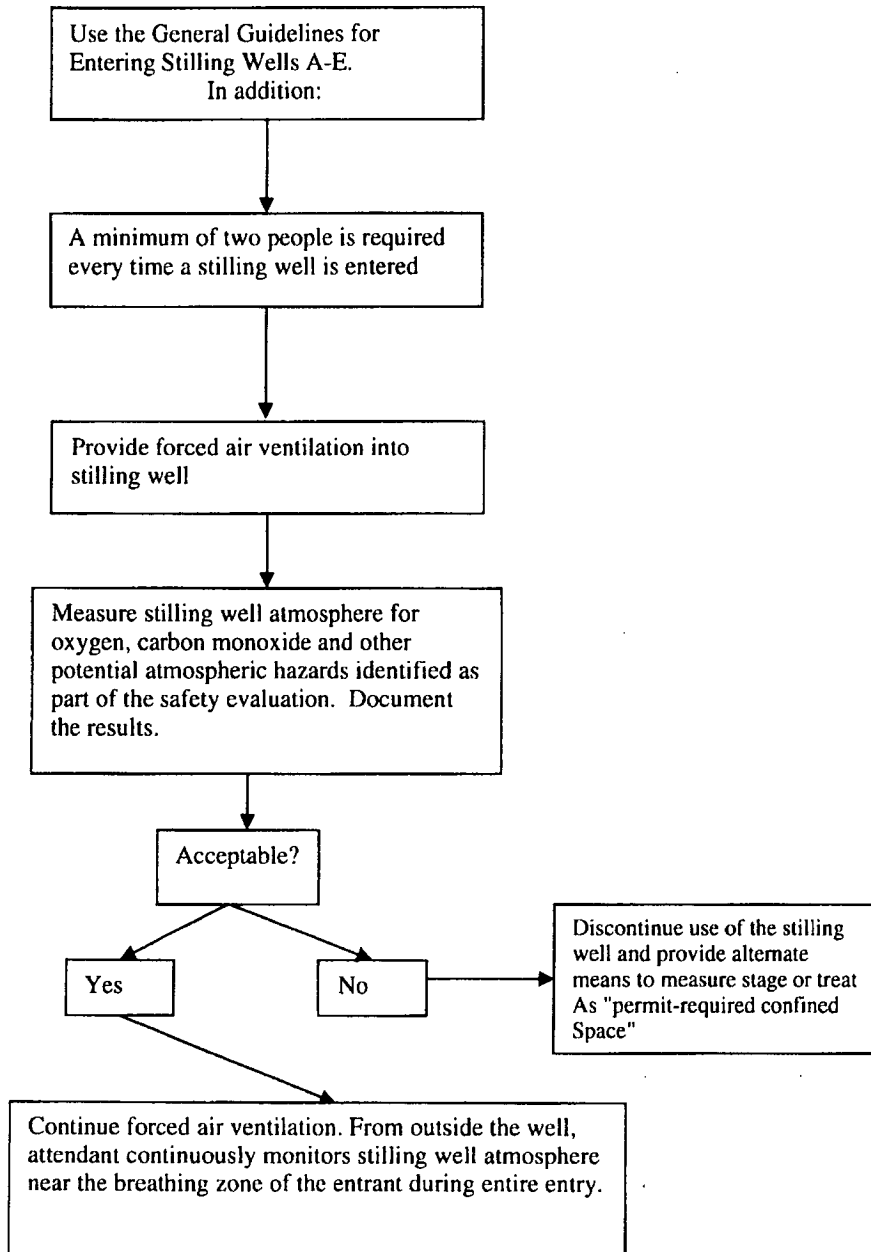



Appendix F

Frequently Asked Questions

**Do all stilling wells have a confined space hazard?

No. If a stilling well does not have a confined space hazard there is no need to use the entry requirements described in this memorandum.

**How can one determine if a stilling well has a confined space hazard?

If your answer is yes to these questions, you have a confined space hazard:

- Is the space large enough that a person can bodily enter?
- Is the space configured so that a worker can perform work inside?
- Does the space have limited or restricted means for entry or exit? (For example: Only one way in and one way out.)
- Does the space have the "potential" to contain a hazardous atmosphere?
- Does the space contain a material that has the "potential" for drowning) an entrant?

**I am uncertain if a specific stilling well has a confined space hazard or not. What should I do?

Contact your Regional Safety Officer for an evaluation.

**How do I fix physical hazards in the stilling well if it is required that all hazards be eliminated before entry.

Eliminate all hazards that do not require entry first, then perform atmospheric tests. If atmospheric tests indicate no hazards, provide forced air ventilation and enter the well to resolve any physical hazards.

**Do I need to provide safety evaluations and atmospheric tests annually even if it may not be necessary to enter the stilling well for three years?

No. Safety evaluation need only be performed 12 months prior to entry or just before entry. If entry isn't required over a several year time span, the safety checks and atmospheric testing is only required just before entry.

**It has been 13 months since the last safety evaluation and atmospheric test. Do I need to repeat the safety evaluation and atmospheric tests prior to entry?

Yes

**If a stilling well failed an atmospheric test in 1999, but subsequent atmospheric tests in later years fail to identify the hazards again, do I need to continue completing the more strict entry requirements?

Yes. Intermittent atmospheric hazards constitute a significant hazard. However, if the cause for the hazardous atmosphere can be positively identified and eliminated, send the documentation to your regional safety officer who will determine if it is ok to step back to the general entry requirements.

**I'm using a propane heater to warm a stilling well in the winter. I need to enter the stilling well for five minutes or less. Do I need to complete the strict entry procedures?

Yes. Using propane heaters in the confined space of a stilling well is very hazardous.

**Do I need to use forced air ventilation every time I enter a stilling well?

Yes, if the stilling well has a confined space hazard.

**Should all gaging station structures, that have AC electrical power, have Ground Fault Circuit Interrupter (GFCI) devices installed?

Yes. GFCI devices provide considerable protection from electronic shock at a very low cost.

**It has been reported that high humidity in some gaging station locations may be causing the GFCI device to trip causing lost record. Are there alternatives to using GFCI devices in all gages?

A very cautious yes. It is recommended that in situations where GFCI devices seem to be tripping unexpectedly, additional efforts be made to identify other factors that may be causing the device to trip. Battery backup can be used to prevent record loss. If GFCI devices continue to trip unexpectedly, contact your regional safety officer who can help identify alternatives to protect field personnel from electrical shock hazards.

**If the use of a stilling well is discontinued, does this mean the structure must always be removed?

No. The structure can continue to be used as an instrument shelter as long as modifications are made to ensure personnel can never enter the stilling well.

**I need to enter a non-USGS stilling well operated by a cooperator. DO I still need to follow the new guidelines?

Yes, if there is a confined space hazard.

**A cooperator wishes to enter a USGS stilling well with a confined space hazard. Does the cooperator need to follow the new guidelines?

Yes

JOB HAZARD ANALYSIS

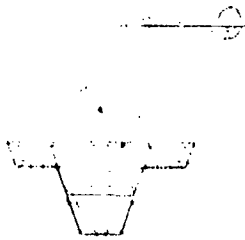

U. S. Geological Survey CABLEWAYS

DATE:10-10-02

NEW
 REVISED

EMPLOYEE/OPERATOR:

All Employees: If it is evident that rescue would be dangerous or difficult to execute the measurement or sampling must not be attempted. The streamgager should consider what will happen should he or she lose control and fall into the water.

It is USGS policy to comply with Federal Aviation Administration (FAA) recommendations regarding use of aircraft warning markers at cableways. A request for an FAA aeronautical study requires the submission of a completed FAA Form 7460-1, Notice of Construction or Alteration to your FAA Regional Office. The FAA provides this service at no cost to the USGS.

CRITICAL: FOLLOW THE INFORMATION PROVIDED IN THE SITE SPECIFIC JHA.

Needed equipment: Gloves, PFD, Cable-cutters, Fall protection for platforms >20 ft. Do not climb ladders while carrying other equipment

Report any vandalism to the District Chief and Annual Safety Inspector(s).

Pre-use inspection training at:
<http://www.rcamnl.wr.usgs.gov/sws/cableways/>

Annual Safety Inspections must be performed by qualified personnel who certify the safety of the cableway and components. Any site not meeting inspection criteria will be removed from service until all repairs are completed. Cable cars must be removed or locked with a lock other than 2640 if the system is unsafe.

TOPICS

REQUIRED ACTIONS OR PERSONAL PROTECTIVE EQUIPMENT

Inspection Prior to Use

Visual inspection of cableway components must always precede any site use.

Visually inspect: Car, Frames, Backstays, Clips and Connectors, Cable, Anchor, Brakes, Footings, Ladder, Puller, PFD.

Do not attempt to use a cableway for any purpose if the cableway anchors or the support footings are submerged.

PFD's

Personal Flotation Devices (PFD's) are required in all operations near, in, or over water except in those cases where an approved site-specific Job Hazard Analysis (JHA) defines the conditions for an exemption. Suspender-type self-inflating PFD's may be worn in lieu of U.S. Coast Guard-approved PFD's for working near, in, or over water on a cableway, bridge, on ice, on a water retention or control structure; or in wading streams. Only those persons who have completed the "over water" safety training may perform cableway activities. See WRD Memo 2000.11 and USGS Manual 445-2-H 4-G

Following Safety Policy

WRD management is responsible to ensure that all safety policies are implemented and monitored at the field level. Supervisors must ensure that employees are informed of safety policies; that the policies are integrated into field operations; and that they are carried out in a proper and consistent manner. Both supervisors and employees will be held accountable if safety policies are not followed. WRD Memo 99.32

Cable Car Integrity

WRD memorandums recommend the use of a stand-up cable-car retrofit kit to strengthen critical structural members. The cable-car retrofit kit will provide for the improved safety of Water Resources Division employees or observers that use cableways. The cable car retrofit kit (part number 2601030) is available from the HIF. (sit-down retrofits expected in FY 03)

Debris

Breakaway cable retrofits are required for all appropriate reels is when debris could lodge on the sounding weight (or other equipment) in the water and place an unmanageable force on the cable. A force on the structure housing the reel can cause damage, loss of equipment, and danger to the streamgager, water sampler, and others in close proximity to the equipment. See WRD Memo 99.01

River Traffic

The sounding cable should have some highly visible system attached to make it easily visible to all boat traffic. District Offices have no doubt used many methods and devices for warning boaters of suspended cables. What is important is that we recognize the potential hazard to boaters, and that we employ effective warning measures. Suspension-cable marking information: <http://www.hif.er.usgs.gov/uo/>

JOB HAZARD ANALYSIS

Safety Hazard
Unauthorized Personnel
DO NOT ENTER

Entry into a confined space is defined as placing any part of the face or body into the space. Common examples of potential confined spaces include stilling wells, well pits, sewers, sewer manholes, most sewer inlets and outfalls, some culverts, vaults, tanks, trenches, pits, pipe assemblies, ducts, silos, storage bins, and hoppers.

Recommended Protective Clothing and Equipment:

Portable electric blower, hard hat, gloves, steel-toed shoes, fall-protection equipment, cell phone, first aid kit, Personal Flotation Device (PFD)

APPLICATION:

USGS personnel and contractors working in any area that is large enough and so configured that an employee can bodily enter and perform assigned work, has limited or restricted means for entry or exit, is not designed for continuous employee occupancy, has poor ventilation, could contain or retain a hazardous atmosphere, or could pose an engulfment or entrapment hazard.



CREW
2

Confined Spaces

Job hazard analyses (JHA's) shall be performed to determine the potential presence of hazardous conditions for tasks requiring entry into a confined space. After completing the JHA, a determination will be made as to whether or not a permit is required.

ANALYSIS BY:

WATER RESOURCES DIVISION POLICY MEMORANDUM NO. 2000.10
USGS SAFETY MANUAL 445-2-H
CHAPTER 40

Emergency Phone Numbers:
Police 777-777-7777
Hospital 888-888-8888
Rescue 999-999-9999

Gage and space safety inspection form:
<http://1stop.usgs.gov/safety/Memos/wrd/wrdpolicy00.10.att3.html>

Place a sign at every entry to the stilling well: "Safety Hazard Unauthorized Personnel DO NOT ENTER"

JOB TASK	POTENTIAL HAZARDS UNSAFE ACTS OR CONDITIONS	REQUIRED PERSONAL PROTECTIVE EQUIPMENT / PROCUDRES
Recognize hazards	If the JHA and applicable air monitoring confirms that the confined space does not contain, or with respect to atmospheric hazards, has potential to contain any hazard capable of causing death or serious physical harm (i.e., no atmospheric hazard, physical stressor, and entrapment or engulfment hazard exists), then a permit is not required and the space shall be classified as a "Non Permit" confined space.	<p>Ensure that the safety evaluation for this site has been completed within the last 12 months.</p> <p>Inspect and document the site: Ladders, Doors, Electrical (GFCI), abate any entrapment hazards.</p> <p>Sample and document the atmosphere: (i.e.) Oxygen, Carbon Monoxide, Hydrogen Sulfide, and Explosive gasses.</p>
Rate the hazards	If the JHA results and applicable air monitoring confirm the confined space contains atmospheric hazard or physical stressor, and/or entrapment or engulfment hazards exist, then the confined space shall be classified as a "Permit Required" confined space.	<p>OPERATIONS IN "PERMIT REQUIRED" SPACES MAY ONLY BE PERFORMED WITH THE WRITTEN PERMISSION OF THE REGIONAL SAFETY MANAGER.</p>
Bad Air	Should an atmospheric hazard exist that can be controlled by continuous forced air ventilation and air monitoring is performed routinely to ensure a non-hazardous atmosphere is maintained, then the confined space does not require individual permitting subject to the conditions of 29 CFR 1910.146(C)(5). However, a confined space program plan and a standard operating procedure (SOP) shall be developed for these spaces.	No less than annual air quality sampling and documented inspections shall be performed in confined spaces where entry is required.

Perform site inspection	Inspect stilling well for hazards such as: * Unsafe ladders- (Ladders over 20 feet long require a fall-protection safety device) * Dangers from falling equipment * Potential for engulfment (drowning) * Electrical hazards (GFCI circuits required) * Biological hazards such as sanitary concerns, snakes, wasps, mice (hantavirus), bats (Histoplasmosis) etc. * If electric power tools are used, they must be double insulated or connected to a GFCI circuit.	
Entering stilling well	Confined Space Hazards Atmospheric Hazards Falling Objects Falling Hazard Entrapment Hazard Have an Emergency Plan	Set up ventilation equipment Fresh air duct should be placed in the stilling well near the water surface. Gasoline-powered equipment must be located downwind and down gradient of stilling well to prevent accidental contamination of the stilling well atmosphere. Secure or remove any equipment that may fall into the stilling well. Set up and wear fall-protection equipment. Wear PFD, Use two people at site.



Summary of Entry Requirements for Stilling Wells that have Failed any Atmospheric Test

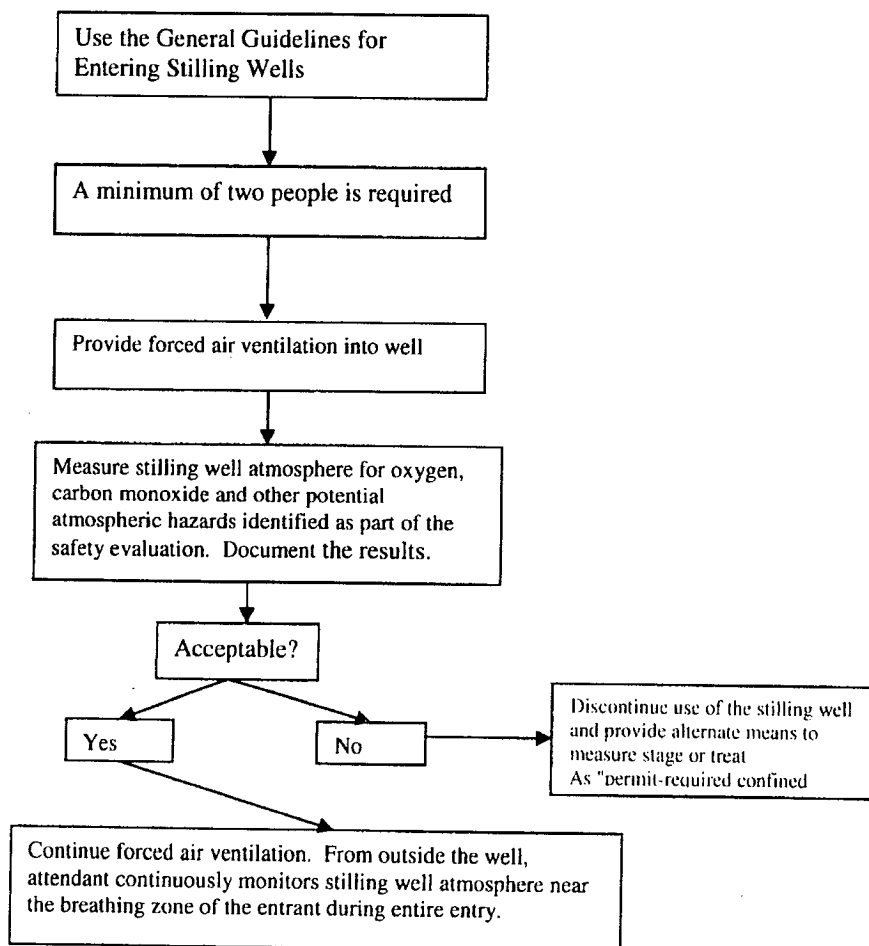



Summary of Basic Entry Requirements for Stilling Wells

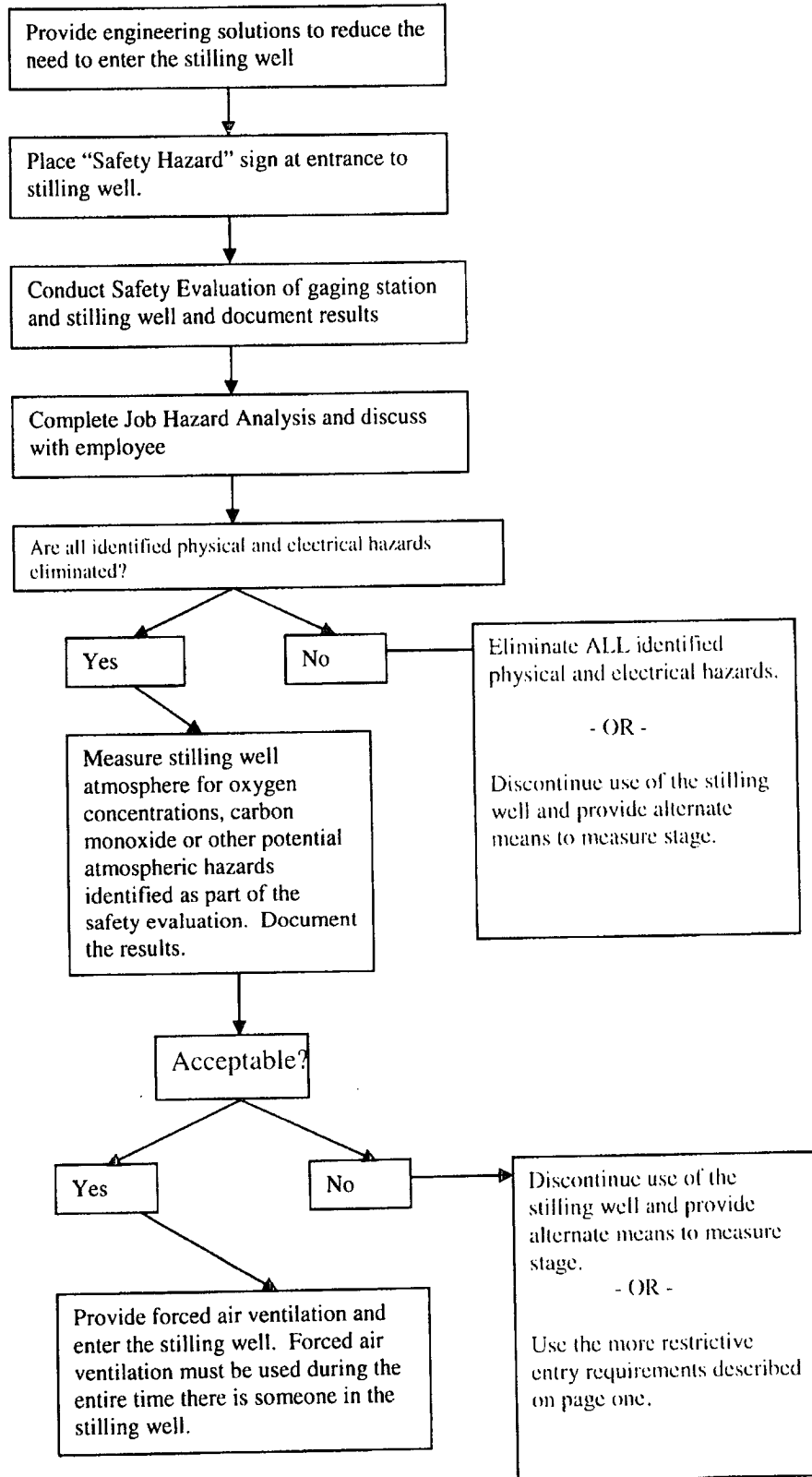

**MS
US DEPARTMENT
US GEOLOGICAL SURVEY**

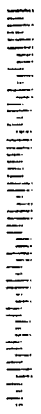

US GEOLOGICAL SURVEY
5231 S 19 ST
LINCOLN, NE 68512-1271

**OFFICIAL BUSINESS
PENALTY FOR PRIVATE USE \$300**

BRIAN DUNNIGAN
DEPT OF NATURAL RESOURCES
PO BX 94676
LINCOLN NE 68509

017H15524259
\$1.340
09/15/2008
Mailed From 68512
HASLER
US POSTAGE

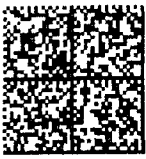

#339



United States Department of the Interior

U.S. GEOLOGICAL SURVEY
Nebraska Water Science Center
5231 South 19 Street
Lincoln, NE 68512-1271

RECEIVED

SEP 16 2008

DEPARTMENT OF
NATURAL RESOURCES

September 15, 2008

Brian Dunnigan
Department of Natural Resources
PO Box 94676
Lincoln, NE 68509-4676

Dear ~~Mr. Dunnigan:~~ 

This is in reference to the Nebraska Department of Natural Resources (NDNR) request to take over the old Republican River near Guide Rock (06853000) streamgaging station about 0.2 mi downstream of the Courtland diversion dam. As I am sure you are aware, the gage has been inactive for a number of years. The U.S. Geological Survey (USGS) was planning to dismantle the facilities at the site because of safety concerns—the stilling well is considered a confined space, and the cableway and car no longer meet USGS standards and are considered unusable in their current condition. There is also a concern about the lack of good access to the site. However, the NDNR is welcome to take the gage over as long as it is understood that they assume responsibility for the gage facilities in an “as is” condition.

Enclosed are two copies of Agreement for Gage Transfer No. 8-8626-06853000. The agreement includes a list of deficiencies in the facilities and a list of USGS safety policies regarding the gage. A requirement of the agreement is that a qualified non-USGS engineer examines the gage and prepares a report that evaluates whether it is suitable for use, with a copy provided to the USGS. Please sign both copies of the agreement and return one copy, along with a copy of the engineer’s inspection report, to this office.

As a required safety measure some time ago, we replaced the standard-keyed USGS padlocks with non-standard ones. The non-standard keys will be needed to gain full access.

Sincerely,

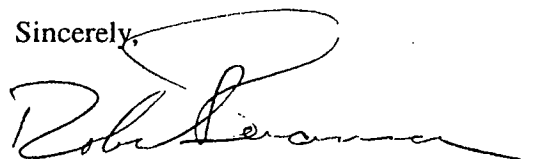

Robert B. Swanson, Director
USGS Nebraska Water Science Center

2 Enclosures